

Middlesex University Research Repository

An open access repository of

Middlesex University research

<http://eprints.mdx.ac.uk>

Shukla, Vinaya ORCID: <https://orcid.org/0000-0002-2546-4931> and Naim, Mohamed M. (2017) Detecting disturbances in supply chains: the case of capacity constraints. International Journal of Logistics Management, 28 (2) . pp. 398-416. ISSN 0957-4093 [Article] (doi:10.1108/IJLM-12-2015-0223)

Final accepted version (with author's formatting)

This version is available at: <https://eprints.mdx.ac.uk/19398/>

Copyright:

Middlesex University Research Repository makes the University's research available electronically.

Copyright and moral rights to this work are retained by the author and/or other copyright owners unless otherwise stated. The work is supplied on the understanding that any use for commercial gain is strictly forbidden. A copy may be downloaded for personal, non-commercial, research or study without prior permission and without charge.

Works, including theses and research projects, may not be reproduced in any format or medium, or extensive quotations taken from them, or their content changed in any way, without first obtaining permission in writing from the copyright holder(s). They may not be sold or exploited commercially in any format or medium without the prior written permission of the copyright holder(s).

Full bibliographic details must be given when referring to, or quoting from full items including the author's name, the title of the work, publication details where relevant (place, publisher, date), pagination, and for theses or dissertations the awarding institution, the degree type awarded, and the date of the award.

If you believe that any material held in the repository infringes copyright law, please contact the Repository Team at Middlesex University via the following email address:

eprints@mdx.ac.uk

The item will be removed from the repository while any claim is being investigated.

See also repository copyright: re-use policy: <http://eprints.mdx.ac.uk/policies.html#copy>



Detecting disturbances in supply chains-The case of capacity constraints

Journal:	<i>International Journal of Logistics Management</i>
Manuscript ID	IJLM-12-2015-0223.R2
Manuscript Type:	Original Article
Keywords:	Supply chain risk, capacity constraint, disturbance detection, clustering

SCHOLARONE™
Manuscripts

Review

Detecting disturbances in supply chains-The case of capacity constraints

Abstract

Purpose – The ability to detect disturbances quickly as they arise in a supply chain helps to manage them efficiently and effectively. This paper is aimed at demonstrating the feasibility of automatically, and therefore quickly detecting a specific disturbance, which is constrained capacity at a supply chain echelon.

Design/Methodology/approach – Different supply chain echelons of a simulated four echelon supply chain were individually capacity constrained to assess their impacts on the profiles of system variables, and to develop a signature that related the profiles to the echelon location of the capacity constraint. A review of disturbance detection techniques across various domains formed the basis for considering the signature based technique.

Findings – The signature for detecting a capacity constrained echelon was found to be based on cluster profiles of shipping and net inventory variables for that echelon as well as other echelons in a supply chain, where the variables are represented as spectra.

Originality/value– Detection of disturbances in a supply chain including that of constrained capacity at an echelon has seen limited research where this study makes a contribution.

Keywords Supply chain risk; capacity constraint, disturbance detection, clustering

Paper type Research paper

1 Introduction

Supply chains are vulnerable to disturbances. Described as unplanned and unanticipated events that disrupt the normal flow of goods and materials in a supply chain and expose associated firms to operational and financial risks (Craighead et al., 2007), disturbances could be catastrophic such as earthquakes, fires, hurricanes and terrorist attacks, or recurring, such as delays in material deliveries, process losses and inappropriate information processing (Chopra and Sodhi, 2004). Together with risks which can be characterized as potential occurrence of disturbances, disturbances in supply chains have been a subject of intense research in recent times (Juttner, 2005; Wagner and Bode, 2008; Thun and Hoenig, 2011; Manuj et al., 2014). The important area of disturbance detection however, appears to have been overlooked.

1 Detecting a disturbance, and doing so early/quickly, enables it to be more efficiently and
2 effectively mitigated as the greater reaction time causes more mitigation options to be available.
3 As an example, consider loss of production capacity at a supplier which could delay incoming
4 supplies at a production facility. An early detection of this disturbance could mean mitigation
5 options such as using alternative suppliers or rescheduling production to produce alternative
6 products or preparing customers for late delivery being available; a delayed detection on the
7 other hand could cause most or all of these options to be unavailable resulting in idling of
8 resources and/or delayed deliveries to end customers with associated penalties, and thereby
9 higher economic consequences (Bodendorf and Zimmermann, 2005).

17 Though the advantages of early supply chain disturbance detection are well recognized
18 (Craighead et al., 2007; Blackhurst et al., 2011), actual interest in this subject as per the extant
19 literature has been limited. In fact, disturbance detection itself is discussed in only a few studies;
20 the discussion is also largely conceptual with the effectiveness of the detection approaches
21 discussed also being questionable. For example, the practice of physically detecting and
22 communicating disturbances as discussed in Svensson (2000) and Norrman and Jansson (2004)
23 is mostly between adjacent and not multiple echelons across supply chains, and whose subjective
24 nature leaves scope for errors in classifying a disturbance as such or disturbances being not
25 reported/misreported.

34 Other more objective and automated approaches such as track and trace that are used in logistics
35 contexts also have limitations, such as disturbances of only a specific kind like delivery delays
36 being detectable, the nature of detection being transactional i.e. lacking in intelligence, and the
37 operational scope of detection being limited to a few echelons (Karkkainen et al., 2004).
38 Similarly, supply chain event management (SCEM) systems, which are an adaptation of track
39 and trace for supply chain contexts and detect discrepancies in ordering and fulfillment processes
40 are also transactional in nature and lack multi-echelon analysis ability i.e. the ability to consider
41 the impact of disturbances in a cascaded structure (Otto, 2003). A need therefore exists for:

- 42 - an information-centric disturbance detection approach (to avoid subjectivity/bias in detection),
- 43 - which uses information from multiple echelons (to enable a supply chain wide detection
44 perspective),
- 45 - with the information being automatically processed through the use of protocols (to enable
46 speed, scale and intelligence in detection), and
- 47 - which could be applied for a variety of disturbances.

Such an approach has been successfully applied in other domains (Davenport and Harris, 2005) but not pursued for supply chain disturbances despite calls to that effect (Christopher and Lee, 2004; Blackhurst et al., 2005). Demonstrating the feasibility of this approach and suggesting a framework for its practical use forms the focus of the exploratory research that we present here. It is aimed at developing a protocol based on system state information, i.e. time series data of variables such as orders, inventory and shipping for automatic, and therefore quick, detection of disturbances in supply chains, with the focus being on a specific disturbance, the capacity constraining disturbance. In theoretical terms, the research contribution can be explained through systems theory (Bertalanffy, 1951) which argues for systems to be treated holistically rather than in terms of its constituent parts. Though this theory has been widely used in generic supply chain work due to the interconnected nature (involving material and information flows) of supply chain entities (Sterman, 2000; Frankel et al., 2008), here it is being used in the context of supply chain disturbance detection and management which is not seen previously. Specifically, negentropy or tendency of systems to reduce entropy, one of the key aspects of systems theory is relevant here, with a 'disturbed' system leaving a trail as it transitions to a more stable/ordered state over time.

The rest of the paper is structured as follows. In the next section we highlight the need for capacity constraint detection in supply chains. In Section 3, we explore techniques being used in different domains to detect disturbances so that related learnings could be applied here. In Section 4, we discuss findings from simulation of a four echelon supply chain system incl. evolution of a protocol for detecting capacity constraint at an echelon. Finally, the practical aspects of applying the protocol based quick disturbance detection approach are discussed in Section 5, which is also the concluding section.

2 Problem statement and capacity constraints

Capacity constraints in supply chains arise frequently and cause significant economic loss through associated delivery delays/short supply to customers (Chopra and Sodhi, 2004; Wagner and Bode, 2008). They are also difficult to avoid given that knowledge of echelon capacities is dispersed across the supply chain (Norrman and Jansson, 2004), and market demand and operations failures that cause capacity constraints are unpredictable in nature. Their choice as a disturbance for developing the protocol based quick disturbance detection approach is therefore appropriate. The protocol in this case should help detect whether a supply chain is capacity constrained, and if so, its echelon location so that appropriate demand and/or supply

1 management related countermeasures could be applied. Such a protocol is not seen in the
2 previous academic literature.
3
4

5
6 Development of the above protocol requires an understanding of the impact of capacity
7 constraints on system variables, which could be best achieved through controlled
8 experimentation. Simulation, specifically control engineering based system dynamics simulation
9 is therefore considered, with a well known four echelon system used in several previous supply
10 chain dynamics studies incl. Sterman (1989) and Shukla et al (2009) being simulated. Although
11 some work on capacity constrained systems using system dynamics modelling has been done
12 previously, the nature of investigation in those studies is different to what is done here. For
13 example, in Wilson's (2007) investigation of system behaviour under loss of capacity, the focus
14 is on the dynamics of inventory and backlogs, while in Spiegler and Naim's (2014) case the
15 emphasis is on the dynamics of shipments. Investigations in these studies are therefore limited to
16 a few/select variables unlike the multiple variable analysis covering orders, shipments and
17 inventory attempted here, and which is also more appropriate given that these variables are all
18 systemically linked. Moreover, previous studies have used the dynamics of variables to
19 understand/improve system performance, while the focus here is to use them and their
20 characteristics to develop a detection protocol.
21
22
23
24
25
26
27
28
29
30
31
32

33 Therefore to summarise, our aim in this study is to develop a protocol based on system
34 information for quick detection of capacity constraint (at an echelon in a supply chain), and
35 thereby demonstrate the feasibility of this kind of an approach for detecting supply chain
36 disturbances in general. Usefulness of this approach however depends on the availability of
37 mitigation options that could utilise the advance disturbance information. The choice of these
38 options however, do not form a part of this study and can be referred to elsewhere (Tomlin,
39 2006; Schmitt and Singh, 2012; Shao and Dong, 2012).
40
41
42
43
44
45

46 **3 Generic disturbance detection techniques and their applicability**

47
48 Our goal here is to briefly outline alternative techniques and assess their suitability for
49 developing the capacity constraint detection protocol. Several domains, where disturbances are
50 automatically (and quickly) detected through techniques based on system information, were
51 identified in the literature. The underlying philosophy is based on Ansoff (1975), who first
52 advocated the use of early warning or weak signals to manage unpredictable, dynamic and hence
53 difficult to plan contexts, and Haeckel's (1999) sense and respond approach, that involves
54
55
56
57
58
59
60

1 sensing changes in dynamic contexts through probes/data and filters/models/data mining
2 methods, and then responding with corrective action/s, if needed. Table 1 below gives these
3 domains, the disturbances encountered therein, the technique/s used for detecting the
4 disturbances and the variable data input to operationalise them. Sub-techniques are not
5 highlighted as our intention is to focus at a generic level.
6
7
8
9

10 -----
11 Add Table 1 here
12 -----

13
14 Looking at Table 1, it is clear that in most domains, predominantly two kinds of techniques
15 termed as anomaly based and signature based are used for disturbance detection. Anomaly based
16 ones involve modeling the behaviour of system variables in statistical terms such as by fitting a
17 probability distribution or a time series model and then monitoring deviations (vis-à-vis
18 usual/normal behaviour), with an alarm being triggered in case of a specified threshold being
19 breached (Basseville and Nikiforov, 1993; Garcia-Teodoro et al., 2009). Though successfully
20 applied in manufacturing contexts for process and quality control (Montgomery, 2005), these
21 techniques have not seen significant application at a supply chain level (MacCarthy and Wasusri,
22 2002), which could be due to challenges such as: 1) Difficulty in stochastic modelling of
23 variables' dynamics for multistage systems such as supply chains (Batson and McGough, 2007;
24 Tsung et al., 2008), 2) Difficulty in specifying thresholds due to the non-stationary nature of the
25 supply chain variable profiles (from the continuous changes in the internal and external
26 environment), 3) Involvement of a large number of system variables in a typical supply chain
27 assessment, where these techniques are known to be less effective (Woodall and Montgomery,
28 1999), and 4) Difficulty in effecting optimal mitigative responses post-detection, as a
29 'disturbed'/'not-disturbed' kind of detection (rather than indication of the specific disturbance
30 impacting a system) is provided by these techniques.
31
32
33
34
35
36
37
38
39
40
41
42
43
44

45 Signature based techniques on the other hand involve formulating signatures, or characteristic
46 profiles of variables associated with specific disturbances, that could subsequently be used to
47 detect them in test cases (Han and Kamber, 2006). These techniques are versatile and not
48 constrained by either the number of variables involved or the nature of their profiles (as gauged
49 by detailed examination of the studies in Table 1 that have applied these techniques). Moreover,
50 the fact that these techniques operate on a pre-specified set of disturbances (for which signatures
51 have been formulated), enables them to determine the exact disturbance affecting a system,
52 thereby enabling specific mitigative actions to be applied. Given these advantages, use of the
53
54
55
56
57
58
59
60

signature based techniques to develop the capacity constraint detection protocol is therefore further explored.

Signatures could be developed through several alternative methods including classification, association and clustering (Ngai et al., 2011), among which the last, i.e. clustering, is the most preferred for time series data (Liao, 2005). Clustering is also relatively easy to interpret and therefore, the signature developed through this method can be expected to have more practical utility. Clustering involves partitioning of data sets into a few homogenous groups or clusters, whose characteristic profiles for individual disturbances could be used as signatures for their detection. Application of this method however, requires choices to be made in terms of: a) System variables whose time series data is to be input, b) Domain in which to represent the data.

The system variables whose time series data is to be input could vary considerably for different collaborative scenarios. However, orders, inventory and shipping are the variables on which information is most commonly shared between organizations (Lee and Whang, 2000; Huang et al., 2003). A signature involving these variables would therefore not only be less complex given the few variables used, it would also encounter less data access problems. Also, as per researchers such as Tang (2006) and Elkins et al. (2008), disturbance detection is possible through such information.

Another important consideration in applying the cluster profiles based signature technique is the domain to be used for representing data. Alternatives include time or features such as autoregressive model coefficients, autocorrelation function, spectra or amplitudes of constituent sinusoids (derived through Fourier transform or FT) and wavelet coefficients derived through discrete wavelet transform of the time series (Liao, 2005). While time domain findings are easier to interpret, data in this domain tends to be noisy which makes signature formulation and application error prone. Representation in the feature domain is therefore increasingly preferred, with spectra considered to be among the most popular features (Keogh and Kasetty, 2003), and which has also been previously tried for supply chain contexts (Shukla et al., 2012). Specific advantages of the spectra include its invariance to time delays that are typically encountered in supply chain contexts and tend to mask underlying profile relationships (Thornhill and Naim, 2006), and its lower sensitivity to missing values. We therefore explore the development of a signature based on cluster profiles of order, inventory and shipping variables, where these variables are represented as spectra, to detect capacity constraint (as the disturbance) in a supply chain.

4.1 System simulated

The well known four-echelon supply chain system of the Beer Game (Sterman, 1989) was simulated for the investigations. Retailer (R), Wholesaler (W), Distributor (D) and Factory (F) are the four echelons in this system where orders flow upstream from the Retailer through to the Factory, and in response, products are shipped downstream. There are delays (also referred to as lead times or LT) in order transmission, shipping and production and a provision for backlogs in case the stock level is inadequate to meet demand. The system is triggered by market demand at the Retailer with individual echelons controlling stock and ordering in each time period. The simulation involved translating the Beer Game system structure and mechanics into difference equations, with the Automatic pipeline, inventory and order based production control (APIOBPCS) heuristic (John et al., 1994) used at each echelon to decide the order quantities.

APIOBPCS, which mimics human behaviour (Sterman, 1989) and is representative of industrial practice (Evans et al., 1997) has been used in previous studies (e.g. Shukla et al., 2009 and Spiegler and Naim, 2014). It can be described as: *the order placed is equal to the average sales rate plus a fraction ($1/T_i$) of the inventory error or the difference between desired and actual inventory plus a fraction ($1/T_w$) of the work-in-process (WIP) error or the difference between desired and actual WIP*, where T_i is the time to adjust inventory and T_w , the time to adjust WIP. The average sales rate is based on exponential smoothing, where T_a or time to adjust demand is related to the exponential smoothing parameter α . While T_p is average delay/lead time between order placement and delivery/production output and is therefore a physical parameter, T_i , T_w and T_a are decision parameters whose values are decided on the basis of criteria such as lower order and inventory variance and greater system responsiveness. For the investigations, 'hard' systems based rational parameter values as per John et al (1994) were considered which are: $T_a = 2T_p$, $T_i = T_p$ and $T_w = 2T_p$. Figure 1 gives the block diagram representation of APIOBPCS, where CONS is the sales rate, AVCONS, the forecast of sales rate, ORATE, the order rate, DWIP and EWIP, the desired and error in work in process levels respectively, AINV, DINV and EINV, the actual, desired and error in inventory levels respectively, and COMRATE, the completion rate or rate of goods receipts into inventory.

 Add Figure 1 here

The difference equations used to simulate the Beer game (including APIOBPCS based ordering) are given in Appendix I. While initial demand at 4 units is considered the same as in Sterman

(1989) (refer equation 2.1a), different demand patterns are considered for subsequent periods (refer equation 2.1b). Equation 2.1c models the delay (lead time or LT) in communicating the order information with delays in material shipments and factory production captured in equations 2.2a and 2.2b respectively. Material shipment dynamics including creation of capacity constraints are represented through equations 2.3 to 2.6; shipment is set to zero when there is no inventory available, and alternatively, when it is available, ordered quantity plus accumulated backlog quantity is shipped subject to adequate shipping capacity being available (as discussed in the next sub-section). Inventory and backlogs are computed separately through equations 2.7 and 2.8 respectively. Sales forecast based on exponential smoothing is calculated through equation 2.9, while the desired, actual and error in inventory and WIP are calculated through equations 2.10 to 2.14. Finally, ordering based on APIOBPCS is captured through equation 2.15, where the parameter values used are as per John et al (1994) discussed earlier.

4.2 *Capacity constraint due to unexpected increase in market demand*

4.2.1 *Analysis in the time domain*

We first analyse capacity constraint from a step change in market demand in a system with a delay/lead time profile of 2,2,3 time units. The related simulation outputs are depicted in figure 2. The profiles are all normalised i.e. they have been mean centered and amplitude scaled to enable comparison.

Add Figure 2 here

Row 1 depicts the variable profiles for the case where no capacity constraints exist. The profiles are all oscillatory with delayed propagation of oscillations from downstream to upstream echelons. Such a behaviour is to be expected given the cascaded system structure, delays in information and material flows, and feedback loops, and which also conforms to that observed for the physical version of the system (Sternan, 1989) thereby verifying the simulation.

The profiles of variables corresponding to the Retailer being capacity constrained are shown in Row II. This involved restricting only the Retailer's maximum shipping capacity to 5 units/time unit. Examination of the Retailer shipping profile shows it to be a step and which is then flat at the increased level for an extended period. While the step can be explained as arising from a

1 similar change in market demand, the subsequent flat profile represents sustained shipping at
2 maximum capacity aimed at eliminating backlogs. The profile for Retailer orders (as seen in
3 Row II, Column A) however, appears to be unaffected and similar to that for the unconstrained
4 case. While intuitively surprising, such a behaviour is logical given that none of the Retailer
5 order quantity determinants are affected by capacity constraint in Retailer shipping: while market
6 demand is considered exogenous, the net inventory gap is unaffected with an increase in
7 backlogs being negated by an equivalent increase in inventory from the inability to ship, and the
8 pipeline gap remaining unchanged given that it is derived from unaffected previous orders. With
9 Retailer orders that wholly drive the dynamics of upstream echelons being unaffected, it is
10 reasonable to expect system variables in those echelons also to be unaffected (vis-à-vis the
11 unconstrained case). Inspection of the order, shipping and net inventory profiles for the
12 Wholesaler, Distributor and Factory echelons confirms this to be the case as seen in Row II.

23 Row III of figure 2 portrays the profiles of variables corresponding to the Wholesaler being
24 capacity constrained. On observing these profiles the following is evident: a step jump in
25 Retailer and Wholesaler shipping, Retailer net inventory steadily moving from a surplus to a
26 backlog position which commences around the time of the step change in market demand, and
27 Retailer orders showing bounded exponential growth i.e. an initial exponential growth which
28 reaches a limiting level over time. These can all be rationally explained.

- 35 1. A step change in market demand causes a sudden increase in Retailer shipping and
36 consequential increase in Retailer orders to the Wholesaler.
- 37 2. The Wholesaler copes by rapidly increasing shipping but given the limited shipping capacity,
38 is only partially able to satisfy the Retailer's orders.
- 39 3. The Retailer's net inventory level therefore starts to reduce and move from a surplus to a
40 backlog position causing a further increase in Retailer orders, whose profile therefore starts to
41 show an exponential increase.
- 42 4. The Wholesaler's inability to completely satisfy Retailer's orders and the resulting
43 accumulation of backlogs causes it to continue shipping at maximum capacity for an extended
44 period of time which explains its shipping profile being flat after the initial step jump.
- 45 5. Accumulation of backlogs at the Retailer requires that it also ship at maximum capacity,
46 which however is constrained by material receipts from the Wholesaler.
- 47 6. Retailer shipping therefore comes to acquire a similar flat profile as Wholesaler shipping after
48 the initial step jump.

- 1 7. As regards other variables, orders placed by upstream echelons i.e. Distributor and Factory
2 orders are seen to retain their oscillatory profiles which are not significantly different from
3 their unconstrained versions despite the cascading affect of increased Retailer orders.
4
- 5 8. The same is true for Distributor and Factory shipping and net inventory, which is not
6 surprising given the systemic linkages between orders and shipping and net inventory
7 variables.
8
- 9 9. Finally, Wholesaler orders and net inventory do not appear to be significantly affected by
10 Wholesaler shipping capacity constraint. The explanation for this is the same as that provided
11 for an analogous situation in case of Retailer capacity constraint.
12
13
14
15
16
17

18 The variable profiles corresponding to capacity constraint at the Distributor are depicted in Row
19 IV. Examination of the variable profiles shows them to be analogous to those for capacity
20 constraint at the Wholesaler.
21
22
23

24 The above investigation was repeated with delay/lead time profile of 3,3,4 time units and a
25 maximum shipping capacity of 6 units/time unit at the constrained echelon, although the relevant
26 plots are not shown here to conserve space. A comparison of variable profiles for the 6 units/time
27 unit maximum shipping capacity case with those for 5 units/time unit showed the difference
28 between the two to be marginal, while those for delay/lead time profiles of 3,3,4 and 2,2,3 time
29 units were seen to be lags/leads of each other, but with similar characteristics.
30
31
32
33
34
35

36 While in the above discussion, variable profiles corresponding to (shipping) capacity constraint
37 at different distribution echelons could be rationalized, the next step is to do an inter-echelon
38 comparison, in order to identify distinguishing characteristics/patterns that could be associated
39 with the echelon location of the capacity constraint. Such a comparison of the plots in figure 2
40 reveals the shipping and net inventory profiles to be providing this discriminating pattern, which
41 can be articulated as: capacity constraint at an echelon is characterized by
42
43
44
45
46

- 47 a) that echelon and all its downstream echelons having similar shipping profiles and which are
48 dissimilar to the shipping profiles for the other echelons,
49
- 50 b) all downstream echelons having similar net inventory profiles which are dissimilar to the net
51 inventory profiles for the other echelons.
52
53
54

55 Applying this to the case of capacity constraint at the Distributor echelon (Row IV) it can be
56 seen that:
57
58
59
60

- 1 a) Shipping profiles for the Distributor and the echelons downstream, i.e. Wholesaler and
2
3 Retailer, are similar but are dissimilar to the shipping profile for the Factory echelon.
4
5 b) Net inventory profiles for the echelons downstream, i.e. Wholesaler and Retailer, are similar
6
7 but are dissimilar to the net inventory profiles for the other echelons, i.e. Distributor and
8
9 Factory.

10
11 Order profiles were not seen to significantly discriminate the (different) echelon locations of
12
13 capacity constraints and were therefore not considered.
14

15 16 *4.2.2 Analysis in the frequency domain and signature formulation*

17
18 The next important step is to explore if the above pattern could be automatically assessed so that
19
20 capacity constraints at echelons could be detected speedily, consistently and at scale. We explore
21
22 the use of clustering, which would mean representing the pattern as an equivalent cluster profiles
23
24 based signature. Clustering however, works on the basis of mathematical precision, and
25
26 therefore, the domain in which to represent variable data would need to be carefully chosen. In
27
28 the time domain, there is a risk of similar but non-aligned profiles, that are typically encountered
29
30 in supply chain contexts from lead times in processing (Thornhill and Naim, 2006; Shukla et al.,
31
32 2012), and also seen in figure 2, being mis-clustered. Use of the spectra representation, or
33
34 amplitudes of sinusoids derived by Fourier transformation of the time series, which is known to
35
36 ignore lags/leads in profile relationships, is therefore explored. Figure 3 depicts the spectra and
37
38 cluster profiles based on the spectra for shipping and net inventory variables, under capacity
39
40 constraints at the Retailer, Wholesaler and Distributor. The spectra are scaled to the same
41
42 maximum peak height to improve visualization. They are seen to stop at 0.5 on the frequency
43
44 axis on account of the Nyquist sampling theorem (Chatfield, 2003), which requires the sampling
45
46 frequency to be at least twice the maximum frequency contained in the data.
47

48
49 -----
50 Add Figure 3 here
51 -----
52

53
54 Examination of the spectra profiles depicted in the first two columns, i.e. Column's A and B, in
55
56 figure 3 shows all of them to have low frequency content, thereby accurately reflecting the trend
57
58 created in the profiles from the step change in market demand. The effectiveness of the spectra in
59
60 capturing lagged/leading profile similarities is also apparent. For example, for the case of
capacity constraint at the Retailer, while in the time domain, the net inventory profiles for
different echelons show a lagged similarity (refer Figure 2, Row II, Column C), they appear to be
similar as such in the spectra representation (refer Figure 3, Row I, Column B), which is also

1 reflected in their being clustered together (refer Figure 3, Row I, Column D). A similar
2 effectiveness of the spectra can be seen for capacity constraints at the Wholesaler and Distributor
3 also. It is important to clarify that Rand Ref seen in figure 3 is a random time series that has been
4 included to better characterize the cluster profiles.
5
6
7
8
9

10 Next, we assess the correspondence between the pattern discussed earlier as applied to capacity
11 constraints at the Retailer, Wholesaler and Distributor and their respective cluster profiles seen in
12 Columns C and D in figure 3; a good correspondence is seen between the two. For example, in
13 the case of the Distributor being capacity constrained, Distributor, Wholesaler and Retailer
14 shipping are seen to be clustered together and away from Factory shipping. Also, the net
15 inventory profiles for the Wholesaler and Retailer are clustered together and away from those for
16 the Distributor and Factory. These cluster profiles correspond exactly with the pattern for
17 capacity constraint being at the Distributor discussed earlier. A similar correspondence is seen in
18 case of capacity constraints at the Wholesaler and Retailer also. Hence, the pattern can be
19 translated into an equivalent cluster profile based signature for locating the capacity constrained
20 echelon. It is given in Table 2 below.
21
22
23
24
25
26
27
28
29
30
31

32 -----
33 Add Table 2 here
34 -----

35 Looking at Table 2, the first three rows are relevant for a three distribution echelon supply chain
36 like the Beer game. However, the last row shows the applicability of the signature for a supply
37 chain with any number of distribution echelons; if for any echelon X in this supply chain,
38 shipping variable for that echelon and shipping variables for all (its) downstream echelons are
39 found to be clustered together and separately from others AND net inventory variables for all
40 downstream echelons (of X) are clustered together and separately from others, then echelon X is
41 indicated as being capacity constrained. Each echelon in the supply chain would need to be
42 tested through the signature in this way; if at the end none is identified as being capacity
43 constrained, then this would indicate the whole supply chain as being un (capacity) constrained.
44 Therefore, detection of both whether a supply chain is capacity constrained i.e. any of its
45 echelons is capacity constrained, and its echelon location is possible through the signature.
46
47
48
49
50
51
52
53
54
55

56 4.3 Capacity constraint due to a reduction in fulfillment capacity 57 58 59 60

1 The previous discussion involved capacity constraint creation from a step change in market
2 demand and the distribution echelon's inability to increase shipping capacity as required. We
3 now consider a reduction in the distribution echelon's shipping capacity as the cause of the
4 capacity constraint, which could be caused by any of equipment/logistics/manpower related
5 failures.
6
7
8
9

10 We first consider a system with a delay/lead time profile of 2,2,3 time units exposed to a
11 constant market demand of 4 units/time unit. While its dynamics is discussed, the related plots
12 are not presented due to a paucity of space. For the case with no capacity reduction, and
13 therefore no capacity constraint creation at any echelon, order, shipping and net inventory
14 profiles were all seen to maintain their initial steady state level as expected. On the other hand,
15 for capacity constraints at the Retailer, Wholesaler and Distributor from reduction in their
16 respective maximum shipping capacities to 2 units/time unit, the dynamics of the shipping and
17 net inventory variables were seen to be analogous to those for capacity constraint from step
18 change in demand in each case, and which can be similarly rationalised. The cluster profiles of
19 the spectra of variables also showed complete correspondence with those given in Table 2 for the
20 three echelons. We next repeated this analysis with Gaussian market demand. The corresponding
21 time series profiles of variables and clustering of their spectra are given in figure 4.
22
23
24
25
26
27
28
29
30
31

32 -----
33 Add Figure 4 here
34 -----
35

36 On examining the variable profiles, their characteristic features for capacity constraints at
37 different echelons appear to be similar to that for the constant market demand case discussed
38 above, and capacity constraint from the step change in market demand case discussed earlier.
39 The cluster profiles of variables show a similar correspondence, and which are as per the
40 signature given in Table 2. Also, alternative delay/lead time profiles of 2,2,3 and 3,3,4 time units,
41 and reduction in the maximum shipping capacity to 1 unit/time unit instead of 2 units/time unit
42 were not seen to significantly affect the profile characteristics, with the signature in Table 2 still
43 found to be valid.
44
45
46
47
48
49

50 Overall, it was possible to develop a signature for detecting the capacity constraint disturbance in
51 a supply chain system. The signature, which is based on time series profiles of variables,
52 specifically their spectra representations and clustering, is intuitive and amenable to automation
53 thereby enabling speed, objectivity and scale in detection.
54
55
56
57
58

59 **5 Discussion and Conclusions**

1 In this study we demonstrated the feasibility of detecting capacity constraint at an echelon in a
2 supply chain through a protocol based on system information, i.e. time series data of system
3 variables. Such a protocol for capacity constrained systems is not seen in the previous literature
4 and is practically relevant given the fluctuations in demand/capacity availability and resulting
5 constraints that are encountered in supply chains. It applies to downstream supply chains, where
6 the time sensitivity of demand and management complexity is greater, and which would
7 therefore particularly benefit from the speed and automation in detection provided by the
8 protocol. A large company/Retailer/3PL player that is managing many downstream supply
9 chains for example could locate capacity constraints quickly, consistently and efficiently through
10 use of the protocol. However, during application, the following would need to be considered:

11
12
13
14
15
16
17
18
19
20 **Availability of system information:** Supply chain wide system information is required to
21 operationalise the protocol. However, this requirement is only for a few variables (shipment and
22 inventory), and which should also be easily accessible for many supply chains (which share
23 information for replenishment efficiency). More generally, the increasing thrust on information
24 exchange and collaboration (Fawcett et al., 2007), further boosted by the discourse on big data
25 and its benefits, where protocols of the kind discussed here are needed (LaValle et al., 2011)
26 means that availability of information can be expected to be less of a hindrance.

27
28
29
30
31
32
33 **Contexts considered for detection:** While generally it would be beneficial to include all supply
34 chains under a common protocol based detection approach to ensure management efficiency and
35 consistency, a selective focus may be more appropriate in some cases. For example, newly
36 established supply chains, supply chains with a history of capacity issues, and supply chains
37 involving critical customers could be separately monitored. Similarly, from a product
38 perspective, the protocol based assessment could be done at an aggregate level or only for certain
39 key/critical products. Blackhurst et al. (2011) provide a good basis for deciding the criticality of
40 supply chains and products from a disturbance management perspective.

41
42
43
44
45
46
47
48 **Mitigation options after detection:** Quick detection of capacity constraint at an echelon would
49 only be useful if appropriate mitigation options could subsequently be quickly deployed. This
50 would be possible only if mitigation options are clearly planned for and specified for each
51 product/entity in the supply chain being assessed through the capacity constraint detection
52 protocol. These options could be based on cost and customer service considerations and could
53 include doing nothing (and accumulating backorders), using alternative shippers, and serving
54 from alternative locations where capacity is available.

1 **Technical aspects:** The protocol is based on cluster profiles of spectra that are not difficult to
2 interpret. However, there are important technical considerations such as frequency of data
3 sampling, length of data to be used to develop the cluster profiles, and frequency of the protocol
4 based assessment. The frequency of data sampling could be based on the transaction (volume)
5 dynamics while a rolling window of appropriate data length that effectively balances sensitivity
6 and false alarm considerations in detection could be used to develop the clusters profiles. The
7 frequency of doing the protocol based assessment could be determined on the basis of the
8 tradeoff between the increased effort/cost associated with more frequent assessments and the
9 benefits from earlier detection.
10

11 While this study's focus was on a specific disturbance, and only on developing a protocol for its
12 (speedy) detection, the process used can be replicated for other disturbances. A company
13 interested in detecting different disturbances in various supply chains under its management
14 could follow an approach where:
15

- 16 a) Representative systems dynamics models of supply chains are first created and specific
17 disturbances individually applied to investigate and understand their impact on the profiles of
18 system variables,
19
- 20 b) The discriminating characteristics, as reflected in the profiles of specific system variables for
21 those disturbances, are then developed into separate signatures/protocols for their quick
22 detection,
23
- 24 c) These signatures/protocols are then made a part of a centralized disturbance management
25 system, where based on relevant time series data of variables as inputs, the associated
26 disturbances could be quickly detected. Specific mitigation options that have been planned for in
27 advance for each disturbance are then quickly activated.
28

29 Such an approach would be most suited for recurring disturbances. This is because
30 signatures/protocols presuppose repeating characteristics, and also the fact that the accumulated
31 cost impact of these disturbances would be significant, and also quantifiable, which would
32 enable investment in a disturbance management system to be justified.
33

34 This study, while contributing in terms of developing a protocol for detecting capacity
35 constraints in supply chains, also has some weaknesses which create opportunities for further
36 research. One limitation is the use of a sequential chain for the investigation. It would be useful
37

1 to consider different supply network configurations to assess the effectiveness of the protocol.
2
3 Use of empirical data, though difficult to get for a capacity constrained system, could also be
4
5 explored for validating the protocol. Another stream of research could be to try to develop
6
7 signatures/protocols for some of the other recurring disturbances affecting supply chains.
8

9 10 **References**

- 11 Ansoff, H. I. (1975), "Managing strategic surprise by response to weak signals", *California*
12 *Management Review*, Vol. 18 No. 2, pp. 21-33.
- 13 Basseville, M. and Nikiforov, I. V. (1993), *Detection of Abrupt Changes: Theory and*
14 *Application*, Prentice Hall, Englewood Cliffs.
- 15 Batson, R. G. and McGough, K. D. (2007), "A new direction in quality engineering: Supply
16 chain quality modelling", *International Journal of Production Research*, Vol. 45 No. 23, pp.
17 5455-5464.
- 18 Bertalanffy, L. (1951), "General Systems Theory: A New Approach to Unity of Science",
19 *Human Biology* Vol. 3, pp. 23-29.
- 20 Blackhurst, J., Craighead, C. W., Elkins, D. and Handfield, R. B. (2005), "An Empirically
21 Derived Agenda of Critical Research Issues for Managing Supply-Chain
22 Disruptions", *International Journal of Production Research*, Vol. 43 No. 19, pp. 4067-4081.
- 23 Blackhurst, J., Dunn, K. S. and Craighead, C.W. (2011), "An Empirically Derived Framework of
24 Global Supply Resiliency", *Journal of Business Logistics*, Vol. 32 No. 4, pp. 374-391.
- 25 Bodendorf, F. and Zimmermann, R. (2005), "Proactive Supply-Chain Event Management with
26 Agent Technology", *International Journal of Electronic Commerce*, Vol. 9 No. 4, pp. 57-89.
- 27 Bolton, R. J. and Hand, D. J. (2002), "Statistical Fraud Detection: A Review", *Statistical*
28 *Science*, Vol. 17 No. 3, pp. 235-249.
- 29 Chatfield, C. (2003), *The Analysis of Time Series: An Introduction*. 6th ed. Boca Raton, Florida:
30 Chapman and Hall/CRC.
- 31 Chopra, S. and Sodhi, M. S. (2004), "Managing Risk to Avoid Supply-Chain Breakdown", *MIT*
32 *Sloan Management Review*, Vol. 46 No. 1, pp. 53-61.
- 33 Christopher, M. and Lee, H. (2004), "Mitigating Supply Chain Risk through Improved
34 Confidence", *International Journal of Physical Distribution & Logistics Management*, Vol. 34
35 No. 5, pp. 388-396.
- 36 Cortes, C. and Pregibon, D. (2001), "Signature-Based Methods for Data Streams", *Data Mining*
37 *and Knowledge Discovery*, Vol. 5 No. 3, pp. 167-182.
- 38 Craighead, C. W., Blackhurst, J., Rungtusanatham, M. J. and Handfield, R. B. (2007), "The
39 Severity of Supply Chain Disruptions: Design Characteristics and Mitigation
40 Capabilities", *Decision Sciences*, Vol. 38 No. 1, pp. 131-156.
- 41 Davenport, T. H. and Harris, J. G. (2005), "Automated Decision Making Comes of Age", *MIT*
42 *Sloan Management Review*, Vol. 46 No. 4, pp. 83-89.
- 43 Diaz, D., Theodoulidis, B. and Sampaio, P. (2011), "Analysis of Stock Market Manipulations
44 using Knowledge Discovery Techniques Applied to Intraday Trade Prices", *Expert Systems*
45 *with Applications*, Vol. 38 No. 10, pp. 12757-12771.
- 46 Elkins, D., Handfield, R. B., Blackhurst, J. and Craighead, C.W. (2008), "A "To-do" List to
47 Improve Supply Chain Risk Management Capabilities", In *Supply Chain Risk Management –*
48 *Minimising Disruptions in Global Sourcing*, edited by R. B. Handfield and K. McCormack,
49 136: Auerbach Publication.
- 50 Evans, G., Cheema, P. and Towill, D. (1997), "Analysis and design of an adaptive, minimum
51 inventory control system", *Production Planning and Control*, Vol. 8 No. 6, pp. 545-557.
- 52
53
54
55
56
57
58
59
60

- 1 Fawcett, S. E., Osterhaus, P., Magnan, G. M., Brau, J. C. and McCarter, M. W. (2007),
2 "Information sharing and supply chain performance: the role of connectivity and willingness",
3 *Supply Chain Management: An International Journal*, Vol. 12 No. 5, pp. 358-368.
- 4 Frankel, R., Bolumole, Y., Eltantawy, R., Paulraj, A., and Gundlach, G. (2008), "The Domain
5 and Scope of SCM's Foundation Disciplines-Insights and Issues to Advance Research",
6 *Journal of Business Logistics*, Vol. 29 No. 1, pp.1-30.
- 7 Garcia-Teodoro, P., Diaz-Verdejo, J., Macia-Fernandez, G. and Vazquez, E. (2009), "Anomaly-
8 Based Network Intrusion Detection: Techniques, Systems and Challenges", *Computers &*
9 *Security*, Vol. 28 No. 1, pp. 18-28.
- 10 Haeckel, S. H. (1999), *Adaptive Enterprise: Creating and Leading Sense-and-Respond*
11 *Organizations*. Boston: Harvard Business School Press.
- 12 Han, J. and Kamber, M. (2006), *Data Mining: Concepts and Techniques*, Elsevier.
- 13 Huang, G. Q., Lau, J. S. K. and Mak, K. L. (2003), "The Impacts of Sharing Production
14 Information on Supply Chain Dynamics: A Review of the Literature", *International Journal*
15 *of Production Research*, Vol. 41 No. 7, pp. 1483-1517.
- 16 Jardine, A. K. S., Lin, D. and Banjevic, D. (2006), "A Review on Machinery Diagnostics and
17 Prognostics Implementing Condition-Based Maintenance", *Mechanical Systems and Signal*
18 *Processing*, Vol. 20 No. 7, pp. 1483-1510.
- 19 John, S., Naim, M. M. and Towill, D. R. (1994), "Dynamic Analysis of a WIP Compensated
20 Decision Support System", *International Journal of Manufacturing System Design*, Vol. 1 No.
21 4, pp. 283-297.
- 22 Juttner, U. (2005), "Supply Chain risk management - Understanding the business requirements
23 from a practitioner perspective", *International Journal of Logistics Management*, Vol. 16 No.
24 1, pp. 120-141.
- 25 Karkkainen, M., Ala-Risku, T. and Framling, K. (2004), "Efficient Tracking for Short-Term
26 Multi-Company Networks", *International Journal of Physical Distribution & Logistics*
27 *Management*, Vol. 34 No. 7, pp. 545-564.
- 28 Keogh, E. and Kasetty, S. (2003), "On the Need for Time Series Data Mining Benchmarks: A
29 Survey and Empirical Demonstration", *Data Mining and Knowledge Discovery*, Vol. 7 No. 4,
30 pp. 349-371.
- 31 Kim, Y. and Sohn, S. Y. (2012), "Stock Fraud Detection using Peer Group Analysis", *Expert*
32 *Systems with Applications*, Vol. 39 No. 10, pp. 8986-8992.
- 33 LaValle, S., Lesser, E., Shockley, R., Hopkins, M.S. and Kruschwitz, N. (2011), "Big Data,
34 Analytics and the Path from Insights to Value", *MIT Sloan Management Review*, Vol. 52 No.
35 2, pp. 21-31.
- 36 Lee, H. L. and Whang, S. (2000), "Information Sharing in a Supply Chain", *International*
37 *Journal of Technology Management*, Vol. 20 No. 3/4, pp. 373-387.
- 38 Leu, S. and Lin, Y. (2008), "Project Performance Evaluation Based on Statistical Process
39 Control Techniques", *Journal of Construction Engineering and Management*, Vol. 134 No.
40 10, pp. 813-819.
- 41 Liao, T. W. (2005), "Clustering of Time Series Data-a Survey", *Pattern Recognition*, Vol. 38 No.
42 11, pp. 1857-1874.
- 43 Liao, H., Lin, C. R., Lin, Y. and Tung, K. (2013), "Intrusion Detection System: A
44 Comprehensive Review", *Journal of Network and Computer Applications*, Vol. 36 No. 1, pp.
45 16-24.
- 46 Lopes J., Belo, O. and Vieira, C. (2011), "Applying User Signatures on Fraud Detection in
47 Telecommunications Networks", Springer Berlin Heidelberg
- 48 MacCarthy, B.L. and Wasusri, T. (2002), "A Review of Non-Standard Applications of Statistical
49 Process Control (SPC) Charts", *International Journal of Quality & Reliability*
50 *Management*, Vol. 19 No. 3, pp. 295-320.
- 51
52
53
54
55
56
57
58
59
60

- 1 Manuj, I., Esper, T.L. and Stank, T. P. (2014), "Supply Chain Risk Management Approaches
2 Under Different Conditions of Risk", *Journal of Business Logistics*, Vol. 35 No. 3, pp. 241-
3 258.
- 4 Montgomery, D. C. (2005), *Introduction to statistical quality control* John Wiley & Sons, New
5 Jersey.
- 6 Ngai, E. W. T., Hu, Y., Wong, Y. H., Chen, Y. and Sun, X. (2011), "The Application of Data
7 Mining Techniques in Financial Fraud Detection: A Classification Framework and an
8 Academic Review of Literature", *Decision Support Systems*, Vol. 50 No. 3, pp. 559-569.
- 9 Nikander, I. O. and Eloranta, E. (2001), "Project Management by Early Warnings", *International
10 Journal of Project Management*, Vol. 19 No. 7, pp. 385-399.
- 11 Norrman, A. and Jansson, U. (2004), "Ericsson's Proactive Supply Chain Risk Management
12 Approach after a Serious Sub-Supplier Accident", *International Journal of Physical
13 Distribution & Logistics Management*, Vol. 34 No. 5, pp. 434-456.
- 14 Otto, A. (2003), "Supply Chain Event Management: Three Perspectives", *The International
15 Journal of Logistics Management*, Vol. 14 No. 2, pp.1-13.
- 16 Raheja, D., Llinas, J., Nagi, R. and Romanowski, C. (2006), "Data Fusion/Data Mining-Based
17 Architecture for Condition-Based Maintenance", *International Journal of Production
18 Research*, Vol. 44 No. 14, pp. 2869-2887.
- 19 Schmitt, A. J. and Singh, M. (2012), "A Quantitative Analysis of Disruption Risk in a Multi-
20 Echelon Supply Chain", *International Journal of Production Economics*, Vol. 139 No. 1, pp.
21 22-32.
- 22 Shao, X. and Dong, M. (2012), "Supply Disruption and Reactive Strategies in an Assemble-to-
23 Order Supply Chain with Time-Sensitive Demand", *IEEE Transactions on Engineering
24 Management*, Vol. 59 No. 2, pp. 201-212.
- 25 Shukla, V., Naim, M. M. and Yaseen, E. A. (2009), "Bullwhip and Backlash in Supply
26 Pipelines", *International Journal of Production Research*, Vol. 47 No. 23, pp. 6477-6497.
- 27 Shukla, V., Naim, M. M. and Thornhill, N. F. (2012), "Rogue Seasonality Detection in Supply
28 Chains", *International Journal of Production Economics*, Vol. 138 No. 2, pp. 254-272.
- 29 Sparks, R., Carter, C., Graham, P., Muscatello, D., Churches, T., Kaldor, J., Turner, R., Zheng,
30 W. and Ryan, L. (2011), "Understanding Sources of Variation in Syndromic Surveillance for
31 Early Warning of Natural or Intentional Disease Outbreaks", *IIE Transactions*, Vol. 42 No. 9,
32 pp. 613-631.
- 33 Spiegler, V. L. M. and Naim, M. M. (2014), "The Impact of Freight Transport Capacity
34 Limitations on Supply Chain Dynamics", *International Journal of Logistics: Research and
35 Applications*, Vol. 17 No. 1, pp. 64-88.
- 36 Sterman, D. J. (1989), "Modeling Managerial Behaviour: Misperceptions of Feedback in a
37 Dynamic Decision Making Experiment", *Management Science*, Vol. 35 No. 3, pp. 321-339.
- 38 Sterman, J. D. (2000), *Business dynamics: systems thinking and modelling for a complex world*,
39 McGraw-Hill, Boston.
- 40 Svensson, G. (2000), "A Conceptual Framework for the Analysis of Vulnerability in Supply
41 Chains", *International Journal of Physical Distribution & Logistics Management*, Vol. 30 No.
42 9, pp. 731-750.
- 43 Tang, C. S. (2006), "Perspectives in Supply Chain Risk Management", *International Journal of
44 Production Economics*, Vol. 103 No. 2, pp. 451-488.
- 45 Thornhill, N. F. and Naim, M. M. (2006), "An exploratory study to identify rogue seasonality in
46 a steel company's supply network using spectral principal component analysis", *European
47 Journal of Operational Research*, Vol. 172 No. 1, pp. 146-162.
- 48 Tomlin, B. (2006), "On the Value of Mitigation and Contingency Strategies for Managing
49 Supply Chain Disruption Risks", *Management Science*, Vol. 52 No. 5, pp. 639-657.
- 50
51
52
53
54
55
56
57
58
59
60

- 1 Thun, J. H., and Hoenig, D. (2011), "An empirical analysis of supply chain risk management in
2 the German automotive industry", *International Journal of Production Economics*, Vol. 131
3 No. 1, pp. 242-249.
- 4
5 Tsung, F., Li, Y. and Jin, M. (2008), "Statistical process control for multistage manufacturing
6 and service operations: a review and some extensions", *International Journal of Services
7 Operations and Informatics*, Vol. 3 No. 2, pp. 191-204.
- 8
9 Unkel, S., Farrington, C. P., Garthwaite, P. H., Robertson, C. and Andrews, N. (2012),
10 "Statistical Methods for the Prospective Detection of Infectious Disease Outbreaks: A
11 Review", *Journal of the Royal Statistical Society. Series A (Statistics in Society)*, Vol. 175 No.
12 1, pp. 49-82.
- 13
14 Wagner, S. M. and Bode, C. (2008), "An Empirical Examination of Supply Chain Performance
15 along several Dimensions of Risk", *Journal of Business Logistics*, Vol. 29 No. 1, pp. 307-325.
- 16
17 Wilson, M. C. (2007), "The Impact of Transportation Disruptions on Supply Chain
18 Performance", *Transportation Research Part E*, Vol. 43 No. 4, pp. 295-320.
- 19
20 Woodall, W. H. and Montgomery, D. C. (1999), "Research Issues and Ideas in Statistical Process
21 Control", *Journal of Quality Technology*, Vol. 31 No. 4, pp. 376-386.
- 22
23
24
25
26
27
28
29
30
31
32
33
34
35
36
37
38
39
40
41
42
43
44
45
46
47
48
49
50
51
52
53
54
55
56
57
58
59
60

1
2 **Table 1- Disturbance detection in different domains**
3
4
5

6 Domain	7 Disturbance detected	8 Detection Techniques	9 Typical information used for detection
10 Banking and Insurance (Bolton and Hand, 2002) 11 (Ngai et al., 2011)	12 Consumer fraud	13 Anomaly and signature based	14 Type, frequency, time, amount and location of purchases (Credit card). Nature, amount and timing of claims and claims process used (Insurance)
15 Telecom (Cortes and Pregibon, 2001) 16 (Lopes et al., 2011)	17 Consumer fraud	18 Anomaly and signature based	19 Geographical origin and destination of call, day of the week, time and duration of call
20 Stock Trading (Diaz et al., 2011) 21 (Kim and Sohn, 2012)	22 Stock price manipulation and fraud	23 Anomaly and signature based	24 Related to stocks such as trading volume, trading venues, market capitalization, price, risk (Beta), financial news and filings, analyst opinions
25 Manufacturing (Raheja et al., 2006) 26 (Jardine et al., 2006)	27 Equipment fault	28 Anomaly and signature based	29 Vibration data, lubricant chemistry, performance characteristics, temperature, acoustic emissions
30 Project Management (Nikander and Eloranta, 2001) 31 (Leu and Lin, 2008)	32 Project failure in terms of cost/time/scope	33 Anomaly based and Judgmental	34 Scope, time schedule, planned and actual cost (Quantitative). Degree of openness/nature of communication, quality/tone of reports exchanged, time taken for decisions, extent of document and budget revisions and changes in personnel (Qualitative)
35 Healthcare (Unkel et al., 2012) 36 (Sparks et al., 2011)	37 Outbreak of disease	38 Primarily anomaly based	39 Extent of absenteeism from work, physician visits, laboratory tests, pharmacy sales, number of telephone calls to emergency services and nature of internet searches
40 Computer Systems (Garcia-Teodoro et al., 2009) 41 (Liao et al., 2013)	42 Unauthorized intrusions/system break-ins	43 Anomaly and signature based	44 Data trail left by users and system activity information like number of accesses, time of day, number of logins/failures, usage of memory, bytes sent

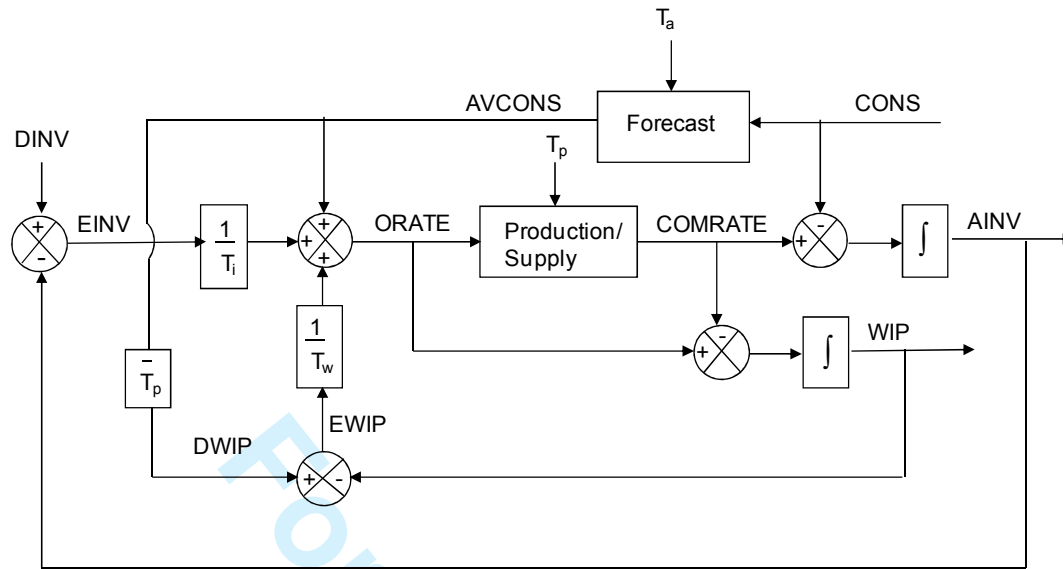

CONS: Consumption/sales rate

AVCONS: Forecast of average consumption/sales rate

ORATE: Order rate

COMRATE: Production completion rate or rate at which orders are fulfilled and goods are received (for Distribution echelons)

AINV: Actual inventory level

DINV: Desired inventory level

EINV: Error between desired and actual inventory level

WIP: Work in process level or Orders in the pipeline (for Distribution echelons)

DWIP: Desired work in process level

EWIP: Error between desired and actual work in process level

T_p : Delay or lead time (LT) in production or between placing orders and receiving goods (for Distribution echelons)

T_i : Time to adjust inventory

T_w : Time to adjust WIP

T_a : Time to adjust demand

Figure 1. Block diagram for a single echelon APIOBPCS system

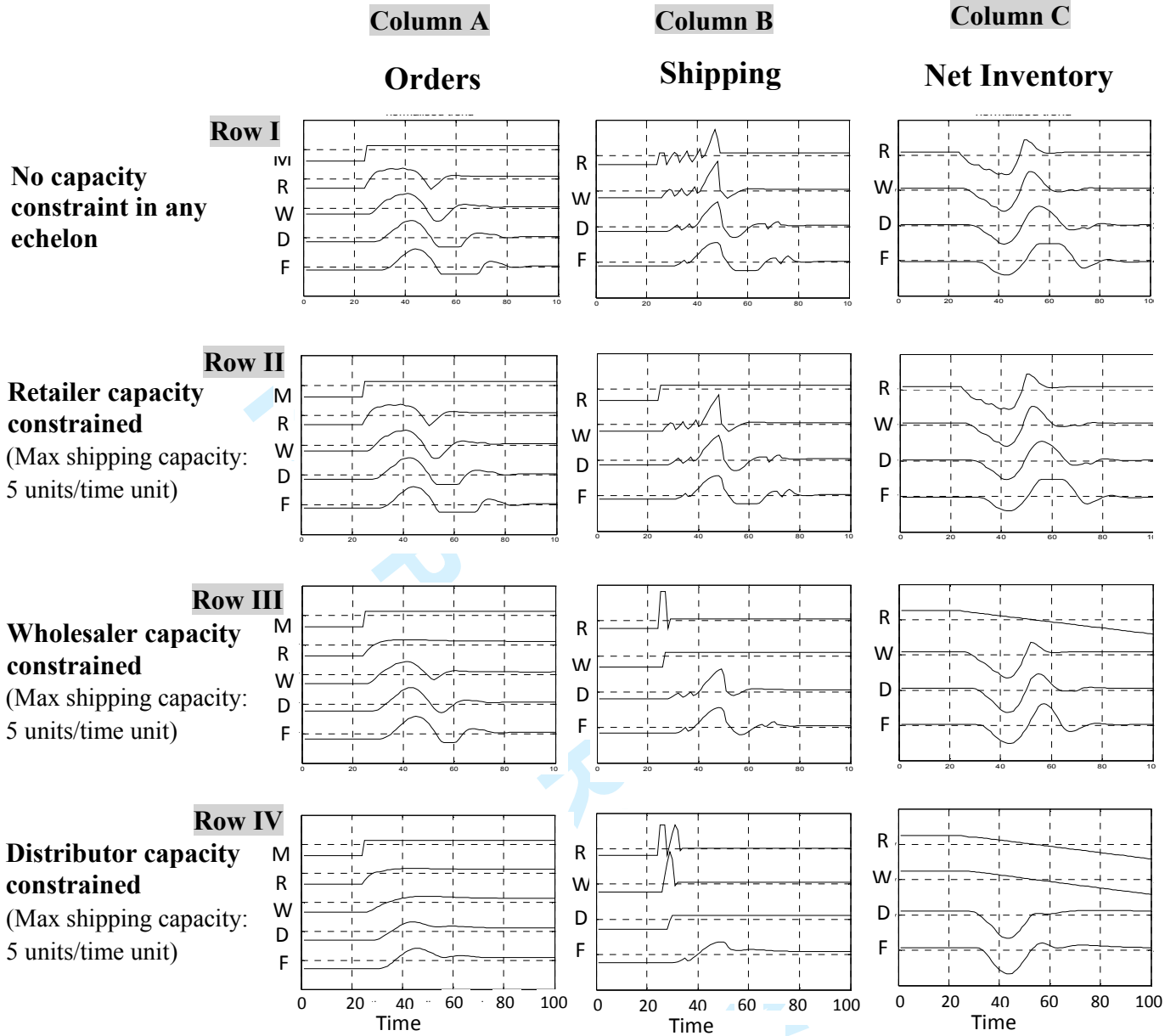

M: Market demand, R: Retailer, W: Wholesaler, D: Distributor, F: Factory

Figure 2: Normalised time series profiles of select variables for a simulated Beer game system under different capacity constraint settings. Beer game system configuration: Step change in market demand from 4 to 8 units/time unit; Delay/lead time profile of 2, 2,3 time units

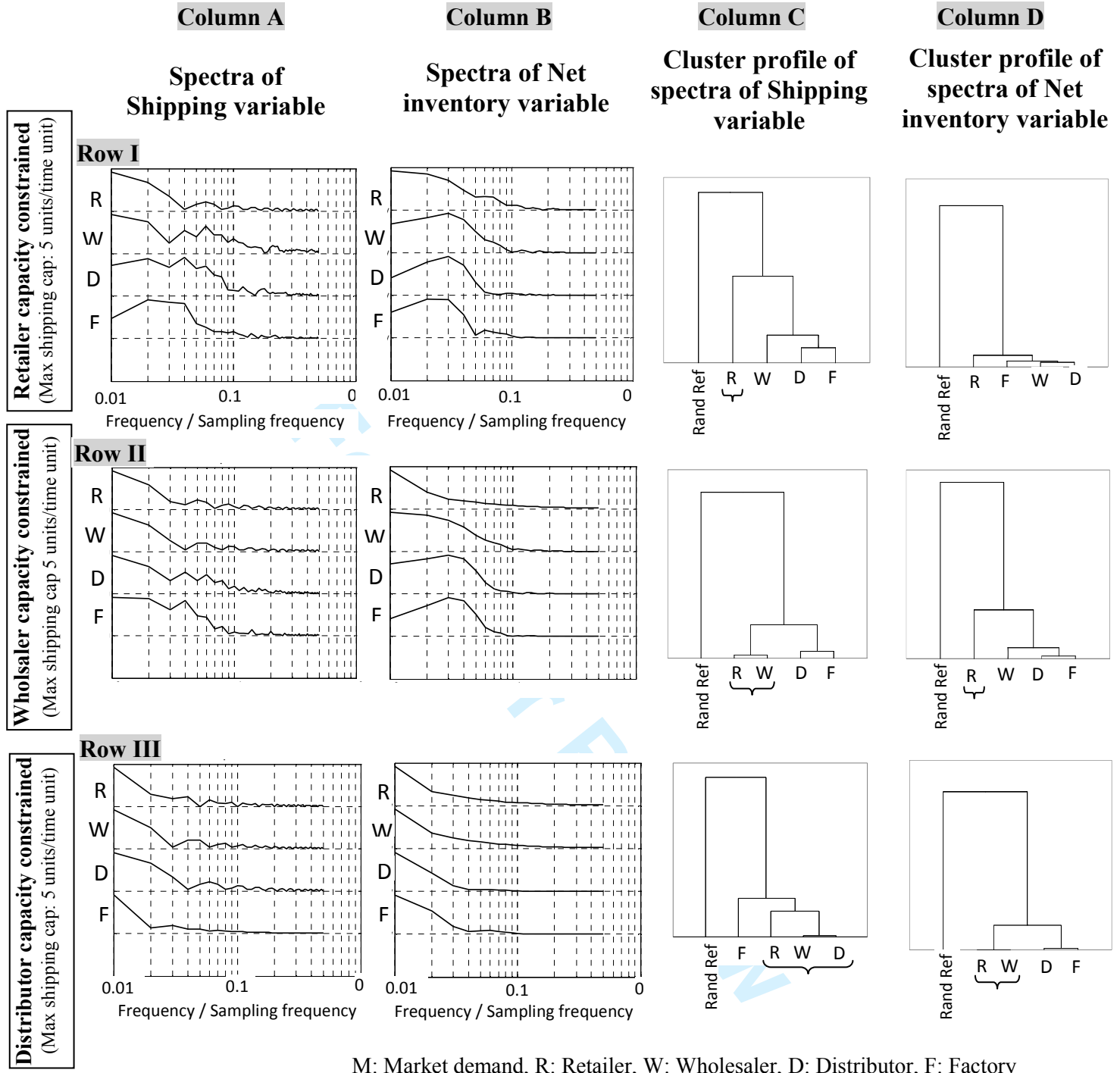

M: Market demand, R: Retailer, W: Wholesaler, D: Distributor, F: Factory

Figure 3: Spectra and their cluster profiles for shipping and net inventory variables for a simulated Beer game system under different capacity constraint settings. Beer game system configuration: Step change in market demand from 4 to 8 units/time unit; Delay/lead time profile of 2, 2,3 time units

Table 2: Signature for identifying capacity constrained distribution echelon in a supply chain

Capacity* constrained echelon	Shipping cluster profile**		Net inventory cluster**profile
Retailer (R)	R shipping clustered separately from others	and	Net inventory for no echelon clustered separately or all clustered together
Wholesaler (W)	R and W shipping clustered together and separately from others	and	R net inventory clustered separately from others
Distributor (D)	R, W and D shipping clustered together and separately from others	and	R and W net inventory clustered together and separately from others
Echelon X	Echelon (X) shipping and shipping of all downstream echelons clustered together and separately from others	and	Net inventory of all downstream echelons (of X) clustered together and separately from others

*Shipping capacity ** Based on spectra of variables

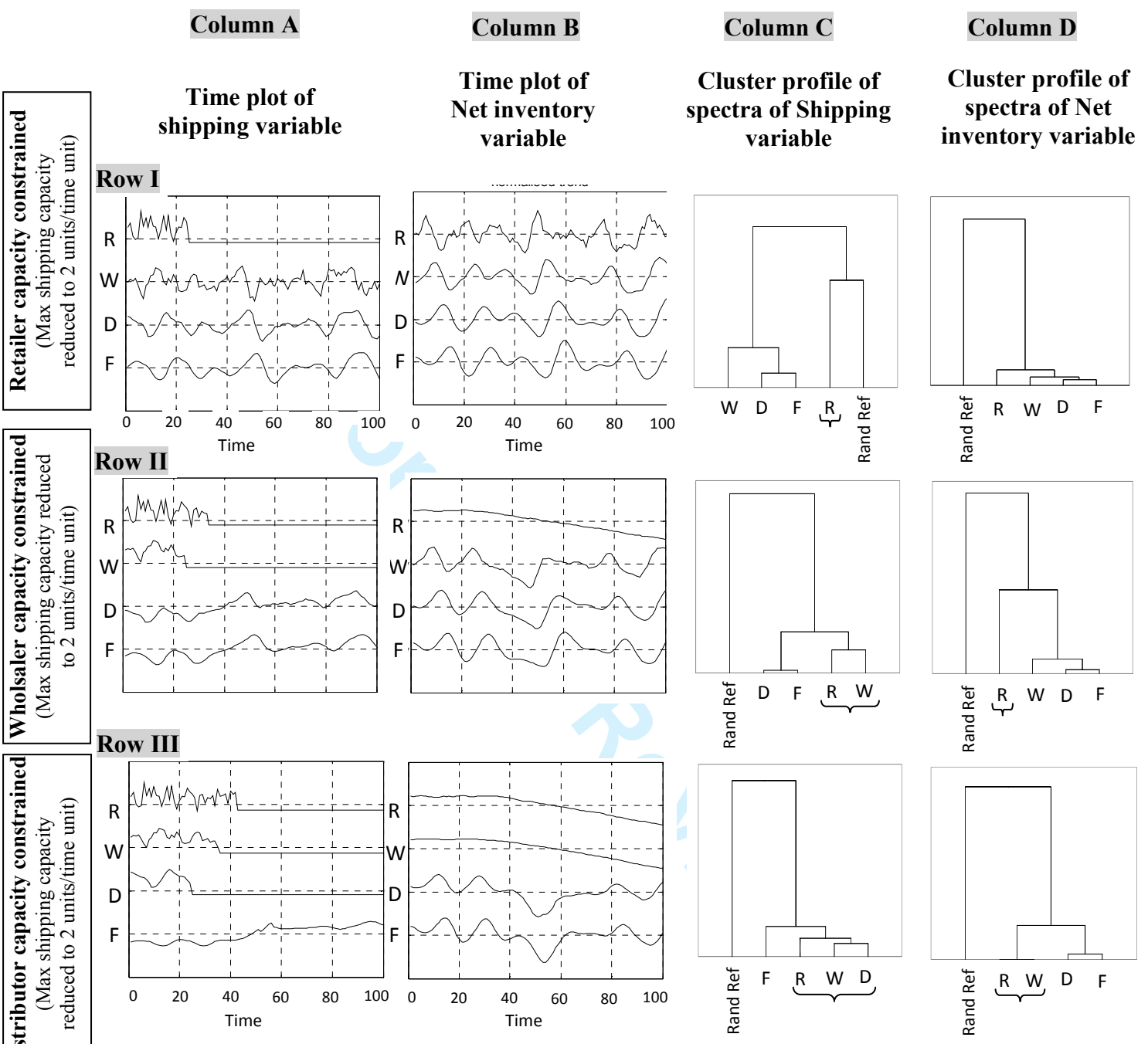

M: Market demand, R: Retailer, W: Wholesaler, D: Distributor, F: Factory

Figure 4: Time series (normalised) of shipping and net inventory variables and cluster profiles of their spectra for a simulated Beer game system under different capacity constraint settings. Beer game system configuration: Market demand: Gaussian (Mean-4 units/time unit, Std dev-1 unit/time unit; Delay/lead time profile of 2, 2,3 time units

Appendix 1. Difference equations used to simulate the Beer game with capacity constrained distribution echelons

J = Supply chain echelon with J = 1, 2, 3, 4 representing the Retailer (R), Wholesaler (W), Distributor (D) and Factory (F) respectively

$$\text{CONS}^J (J = 1 \text{ to } 4, t \leq 24) = 4 \text{ ----- Initial condition; Rest of the equations are for } t > 24 \quad (2.1a)$$

$$\text{CONS}^J (J = 1, t) = 4 \text{ (constant demand) or } = 8 \text{ (step change in demand) or } = 4 + \varepsilon_t \text{ (Gaussian demand process)} \quad (2.1b)$$

$$\text{CONS}^J (J = 2 \text{ to } 4, t) = \text{ORATE}^{J-1} (t - \text{LT}_{\text{order transmission}}) \quad (2.1c)$$

$$\text{Shipment Received}^J (J = 1 \text{ to } 3, t) = \text{Shipping}^{J+1} (t - \text{LT}_{\text{shipping}}) \quad (2.2a) \quad \text{Shipment Received}^J (J = 4, t) = \text{ORATE}^J (t - \text{LT}_{\text{production}}) \quad (2.2b)$$

$$\text{Material Available for Shipping}^J (J = 1 \text{ to } 4, t) = \text{AINV}^J (t-1) + \text{Shipment Received}^J (t) \quad (2.3)$$

$$\text{Desired Shipping}^J (J = 1 \text{ to } 4, t) = \text{Backlog}^J (t-1) + \text{CONS}^J (t) \quad (2.4)$$

$$\text{Maximum Shipping Capacity}^J (J=1 \text{ to } 3, t) = \text{MSC}^J \quad (2.5)$$

$$\text{Shipping}^J (J = 1 \text{ to } 3, t) = \text{MIN} [\text{Desired Shipping}^J (t), \text{Material Available for Shipping}^J (t), \text{MSC}^J] \quad (2.6a)$$

$$\text{Shipping}^J (J = 4, t) = \text{MIN} [\text{Desired Shipping}^J (t), \text{Material Available for Shipping}^J (t)] \quad (2.6b)$$

$$\text{AINV}^J (J = 1 \text{ to } 4, t) = \text{AINV}^J (t-1) + \text{Shipment Received}^J (t) - \text{Shipping}^J (t) \quad (2.7)$$

$$\text{Backlog}^J (J = 1 \text{ to } 4, t) = \text{Backlog}^J (t-1) + \text{CONS}^J (t) - \text{Shipping}^J (t) \quad (2.8)$$

$$\text{AVCONS}^J (J = 1 \text{ to } 4, t) = \text{AVCONS}^J (t-1) + \alpha [\text{CONS}^J (t) - \text{AVCONS}^J (t-1)], \text{ where } \alpha = 1 / (1 + T_a / \Delta t); \Delta t \text{ is simulation time increment set at } 1 \quad (2.9)$$

$$\text{DWIP}^J (J = 1 \text{ to } 4, t) = T_p * \text{AVCONS}^J (t) \text{ where } T_p \text{ is the lead time between placing an order and receiving the} \quad (2.10)$$

material for J supply chain echelon; $T_p (J = 1 \text{ to } 3) = \text{LT}_{\text{order transmission}} + \text{LT}_{\text{shipping}} - 1$; $T_p (J = 4) = \text{LT}_{\text{production}} - 1$

$$\text{WIP}^J (J = 1 \text{ to } 3, t) = \sum_1^{\text{LT}_{\text{order transmission}} - 1} \text{ORATE}^J (t-i) + \sum_0^{\text{LT}_{\text{shipping}} - 1} \text{Shipping}^{J+1} (t-k) + \text{Backlog}^{J+1} (t) \quad (2.11a)$$

$$\text{WIP}^J (J = 4, t) = \sum_1^{\text{LT}_{\text{order transmission}} - 1} \text{ORATE}^J (t-i) \quad (2.11b)$$

$$\text{EWIP}^J (J = 1 \text{ to } 4, t) = \text{DWIP}^J (t) - \text{WIP}^J (t) \quad (2.12) \quad \text{DINV}^J (J = 1 \text{ to } 4, t) = 12 \quad (2.13)$$

$$\text{EINV}^J (J = 1 \text{ to } 4, t) = \text{DINV}^J (t) - \text{AINV}^J (t) + \text{Backlog}^J (t) \quad (2.14)$$

$$\text{ORATE}^J (J = 1 \text{ to } 4, t) = \text{MAX} [0, \text{AVCONS}^J (t) + (\text{EINV}^J (t) / T_i) + (\text{EWIP}^J (t) / T_w)] \quad (2.15)$$

1
2
3
4
5
6
7
8
9
10
11
12
13
14
15
16
17
18
19
20
21
22
23
24
25
26
27
28
29
30
31
32
33
34
35
36
37
38
39
40
41
42
43
44
45
46
47
48
49
50
51
52
53
54
55
56
57
58
59
60

For Peer Review